



HELPFUL TIPS TO PREPARE FOR THE ARRIVAL OF YOUR NEW HOT TUB

Here at Spas and Hot Tubs your peace of mind is paramount. Purchase, delivery and beyond, we're here to help you at every step along the way. Trading since 1999, we're an experienced family run business who'll listen to your requirements and ensure you get the very best service and valuable advice to help you identify the right spa for your needs. Right from your initial contact with us, our experienced sales and technical team will guide and support you all the way through to the process of delivery, installation and commissioning of your chosen spa, and then onward to provide you with excellent after sales care and service. To begin this process, below is a list of useful tips to help you plan for the delivery of your future spa.

Water Supply

There must be an appropriate water supply to fill the spa, usually a hosepipe long enough to reach the spa area. This will also be used to refill your spa when needed throughout the year.

Electricity Supply

Plan to install an appropriate electrical supply, 13amp, 20amp or 32amp depending on which model you choose. If in doubt, we always recommend a 32amp supply is installed where possible. This must be protected by means of a residual current device (RCD). We recommend that any work should be carried out by a qualified electrician in accordance with IEE regulations. We're more than happy to provide full requirements for a specific model when requested.

Base

There must be an appropriate base to hold the weight of the spa (e.g. concrete, slabs/paving or decking). It's not recommended to leave the spa on grass as it may sink and damage the spa.



Access

It's best to consider the access you have around your property. When your spa is delivered, it'll be sited using a special spa trolley (as shown below). The spa will be mounted sideways onto the trolley, so the depth of the spa will become the width, and the width will become the height. If you're unsure about the access you have, we offer a site survey service to check for you. Should you require a crane or Hiab, we'd be happy to help arrange this.

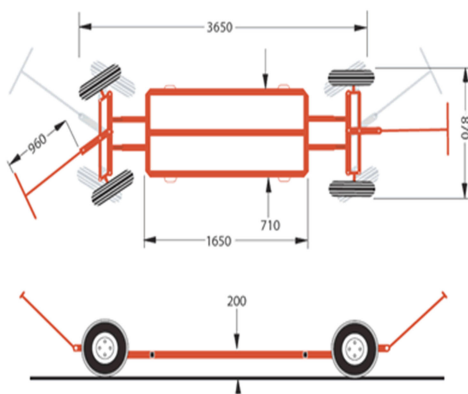

Delivery

Each spa delivery is unique and our expert team will work directly with you to assure your delivery goes smoothly. We'll spend a good amount of time during the installation explaining how to use your new spa and how to use your chemicals correctly.

Should you have any queries, please don't hesitate to contact us 7 days a week

Telephone on: [0116 220 2025](tel:01162202025) or [07793 988 123](tel:07793988123)

Email: info@spasandhottubs.co.uk

Alternatively, visit us at our showroom:

**Palmers at Ullesthorpe Garden Centre. Lutterworth Road, Ullesthorpe,
near Lutterworth LE17 5DR**

Located in South
Leicestershire
with easy access
from M1, M6,
M69 and A5



Softub Midlands Ltd.

Telephone:

[0116 220 2025](tel:01162202025) or [07793 988 123](tel:07793988123)